

BRYAN ROLLINS

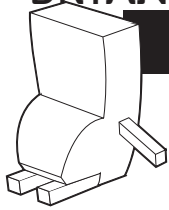

**TUBii**

**SERIES ONE**  
featuring RUN DMC

[www.bryanrollins.com](http://www.bryanrollins.com)

glue

wings

insert wings

fold

body

fold

fold

L side

insert arm

R side

insert arm

legs

arms

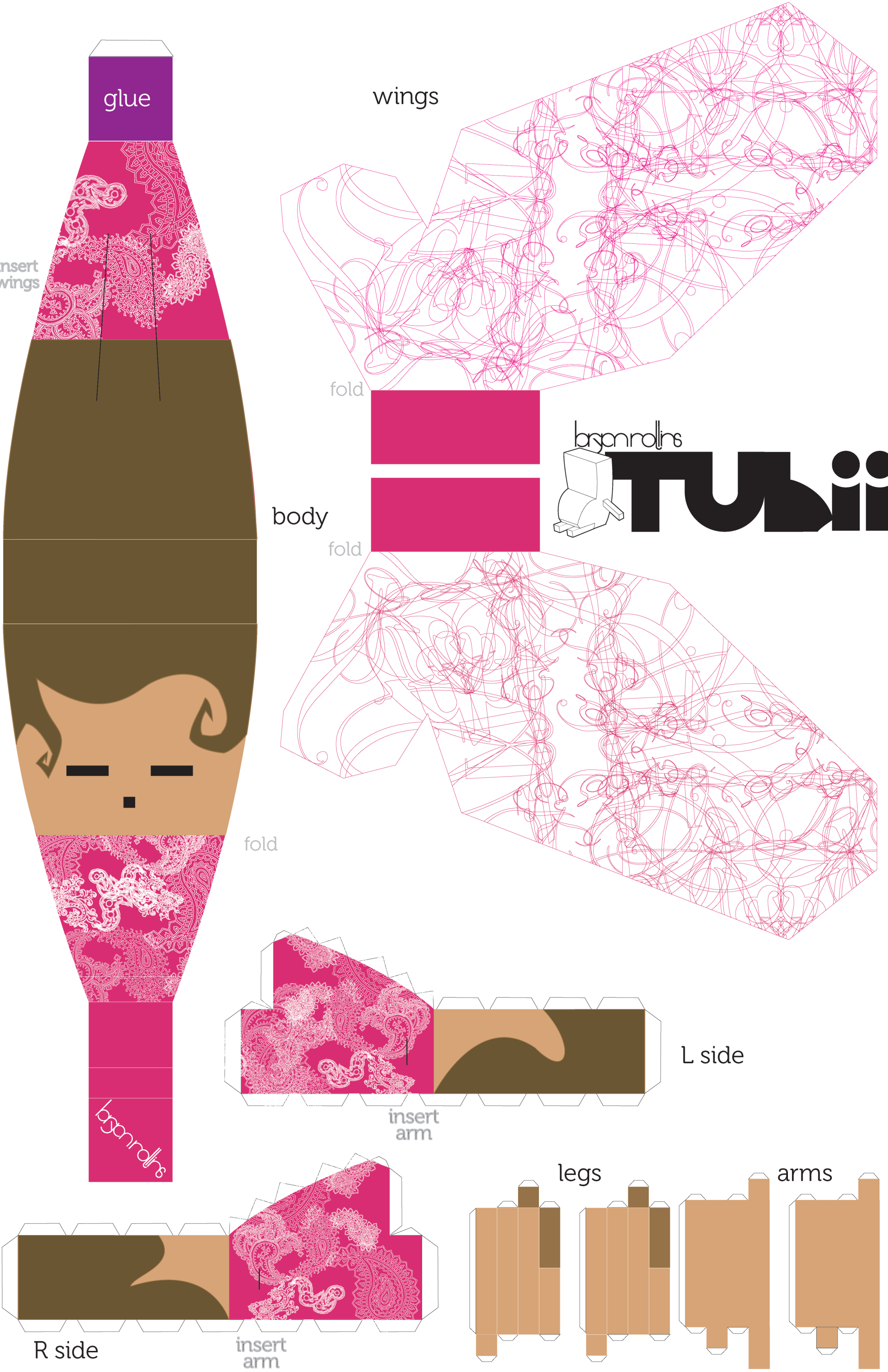

# # 1

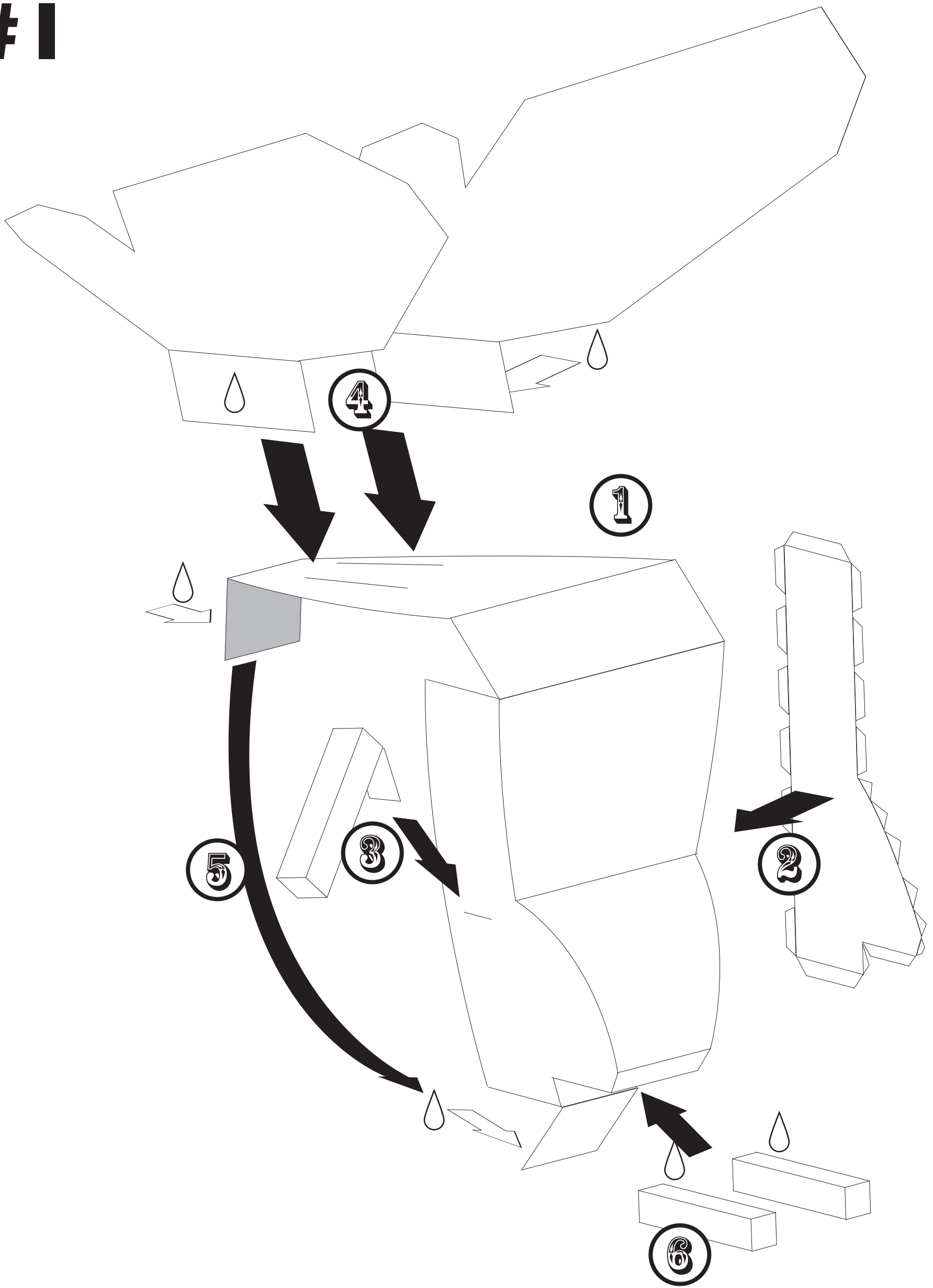

instructions:

1. cut out and fold all pieces.
2. attach sides to front and bottom sections of the body.
3. construct arms and insert flaps into side slits. glue flaps to the inside of the body.
4. slide wings into back portion. glue flaps to the inside of the body.
5. complete body, fold down the back while gluing. the purple flap goes on the inside.
6. construct the legs. place glue on the dark sections of the legs and attach under the belly.



body

do not cut  
past this line

cut along  
dotted lines

cut along  
dotted lines

arms

do not cut  
past this line

L Side

R Side

legs

# #2

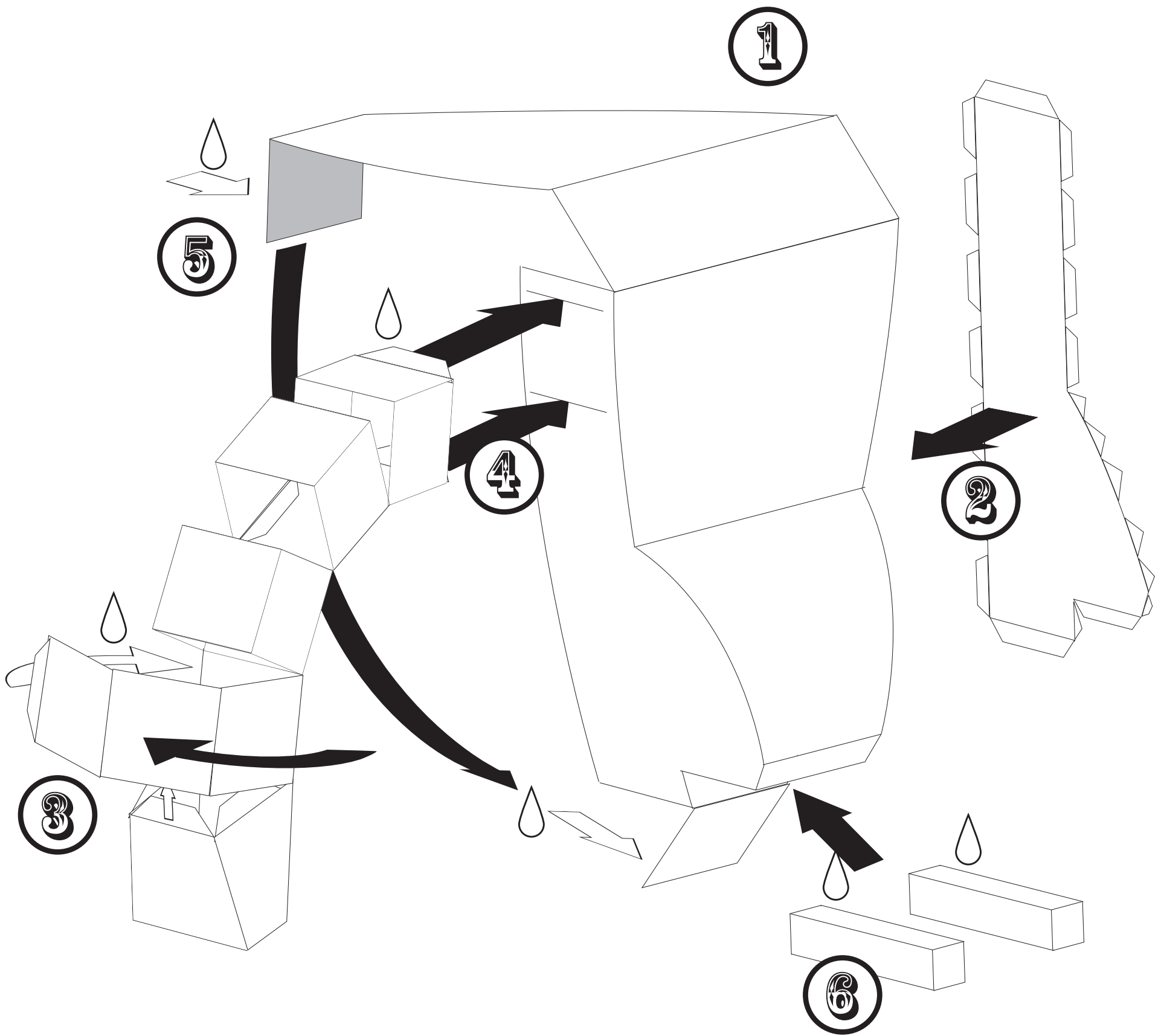

## instructions:

1. cut out and fold all pieces. Use the side panels as guide to fold belly.
2. attach sides to front and bottom sections of the body.
3. construct arms. experiment with different positions.
4. insert flaps into side slits. glue flaps to the inside of the body.
5. complete body. fold down the back while gluing. the purple flap goes on the inside.
6. construct the legs. place glue on the dark sections of the legs and attach under the belly.

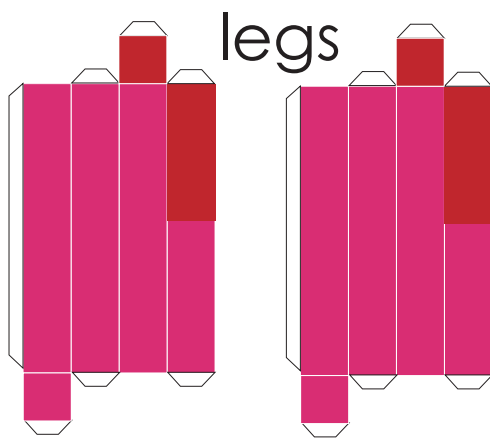
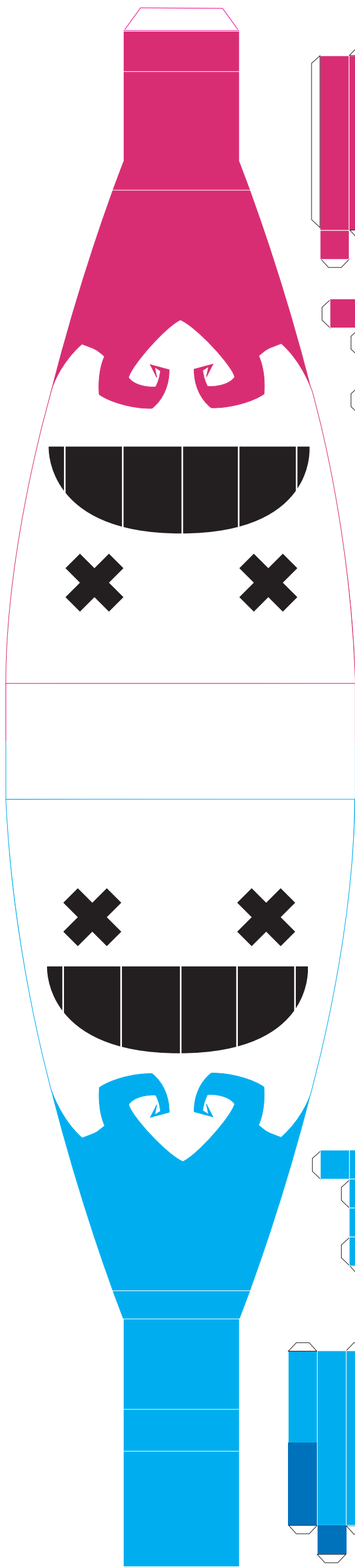

legs

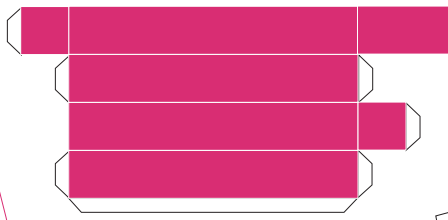

L arm

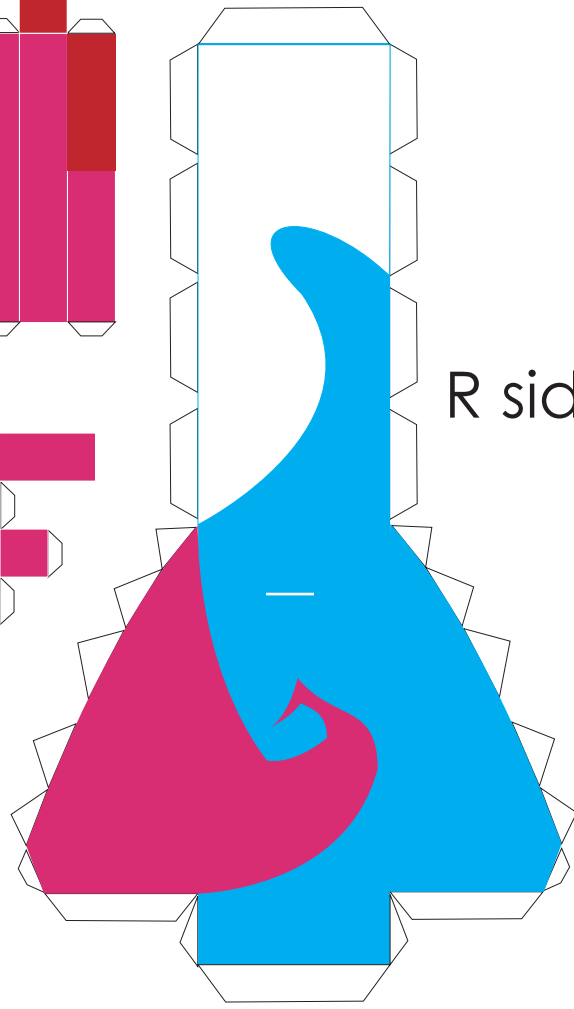

R side

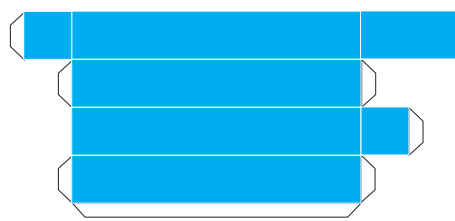

R arm

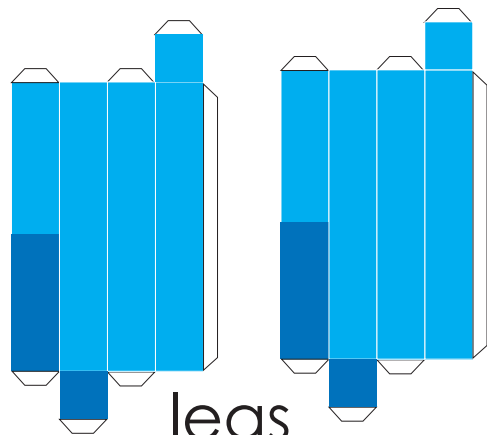

legs

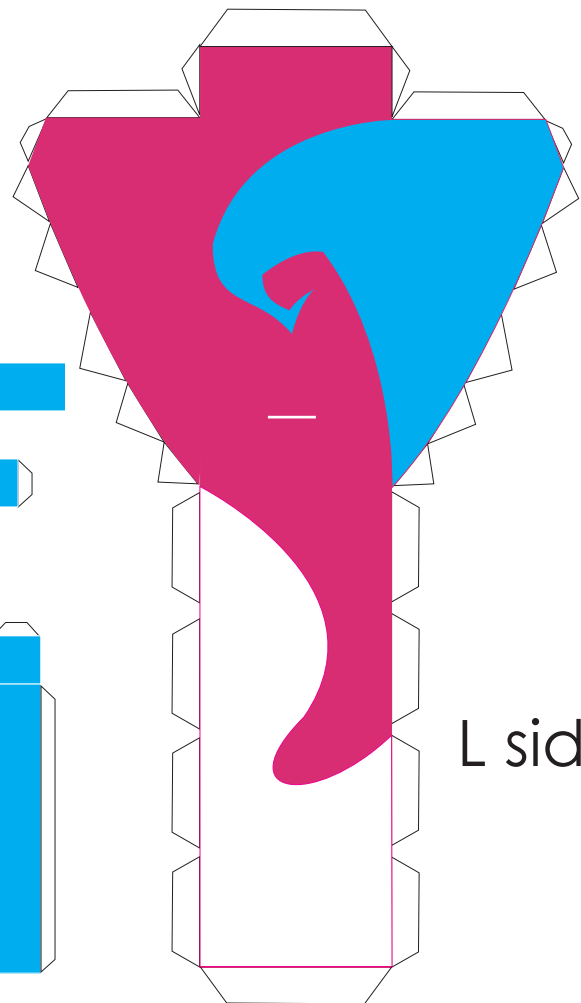

L side

# #3

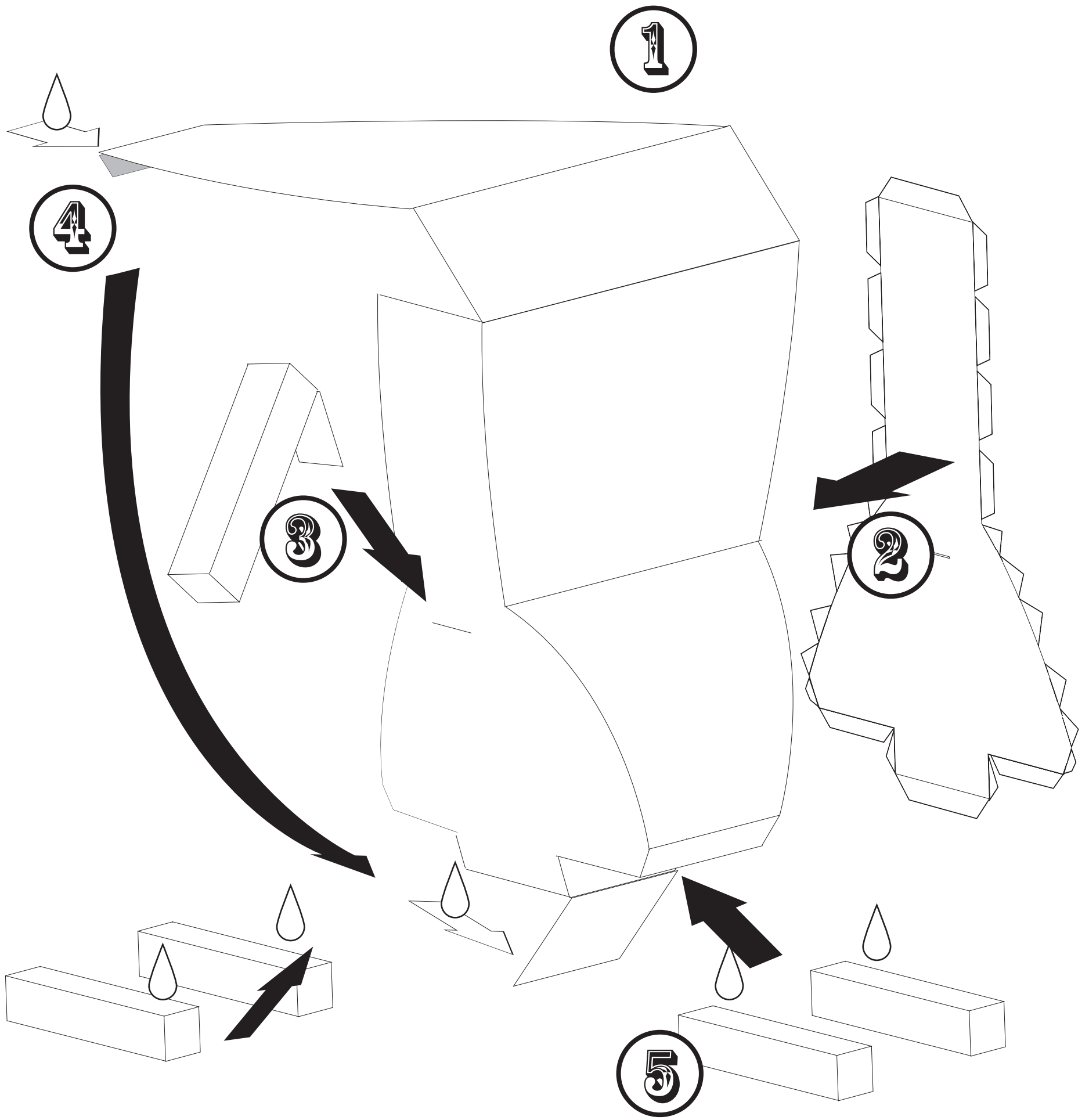

## instructions:

1. cut out and fold all pieces. Use side panels as guides when folding body.
2. attach sides to front and bottom sections of the body.
3. construct arms and insert flaps into side slits. glue flaps to the inside of the body
4. complete body. fold down the back while gluing.
5. construct the legs. place glue on the dark sections of the legs and attach under the belly.





# REVEREND RUN

Joseph Ward Simmons (born November 14, 1964) is one of the founding members of hip hop group Run-D.M.C.. He is known as DJ Run, Joey Simmons or Rev Run, which is a play on his religious title. Born in Hollis, Queens, New York, he is the younger brother of Daniel "Danny" Simmons, Jr and Russell Simmons, Def Jam Records co-founder. He entered the scene via his older brother Russell, as a DJ for his first big act for Kurtis Blow. Joseph "Run" Simmons founded Run-D.M.C. as a lead vocalist (MC) along with MC'ing friend Darryl "DMC" McDaniels and DJ Jason "Jam-Master Jay" Mizell. The group's work is considered to be inventive and original, using numerous revolutionary styles, including the pioneering work of Jam-Master Jay.

— Wikipedia

\*I am not affiliated with RUN DMC, Def Jam Records, inc., or any related properties\*

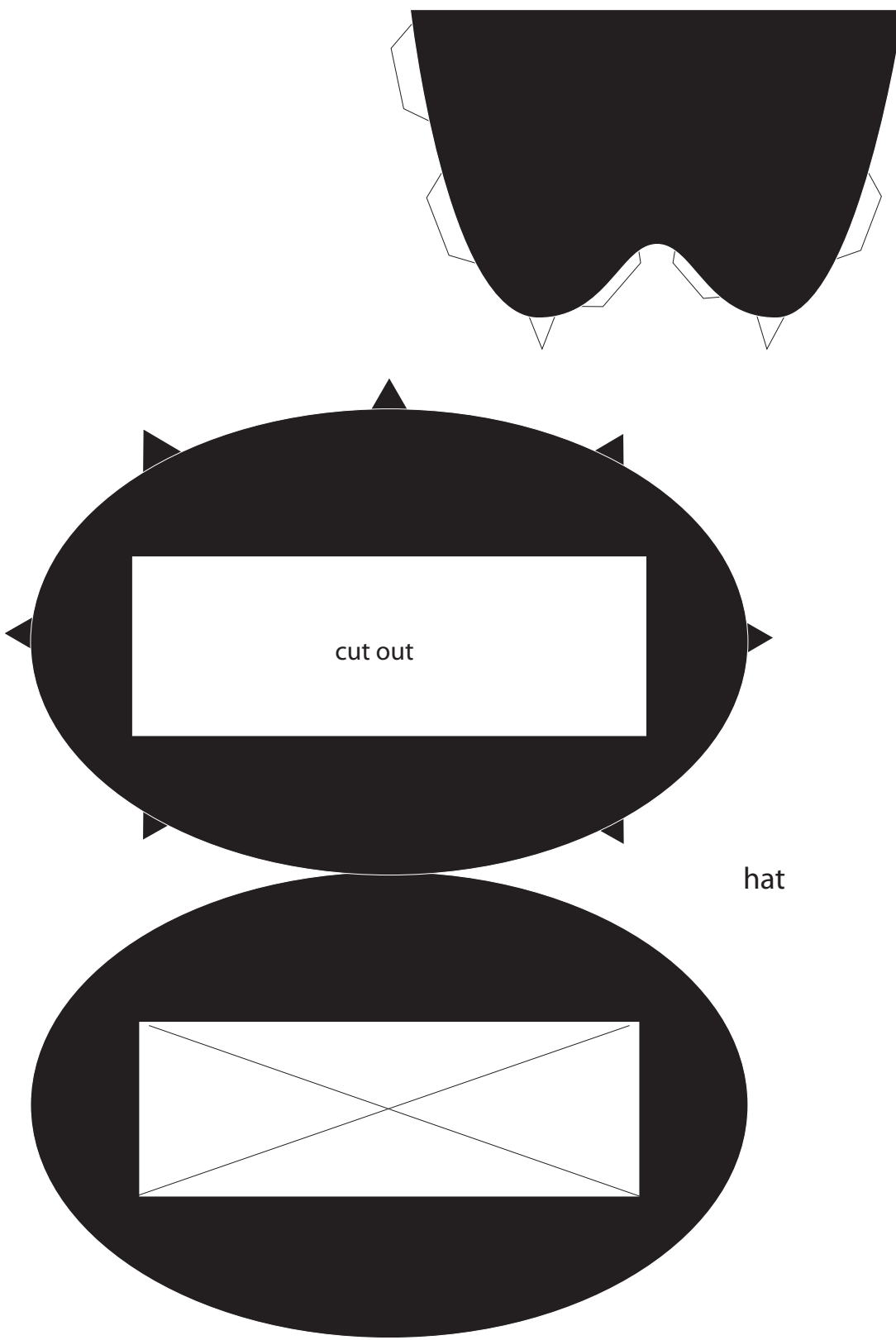

hat

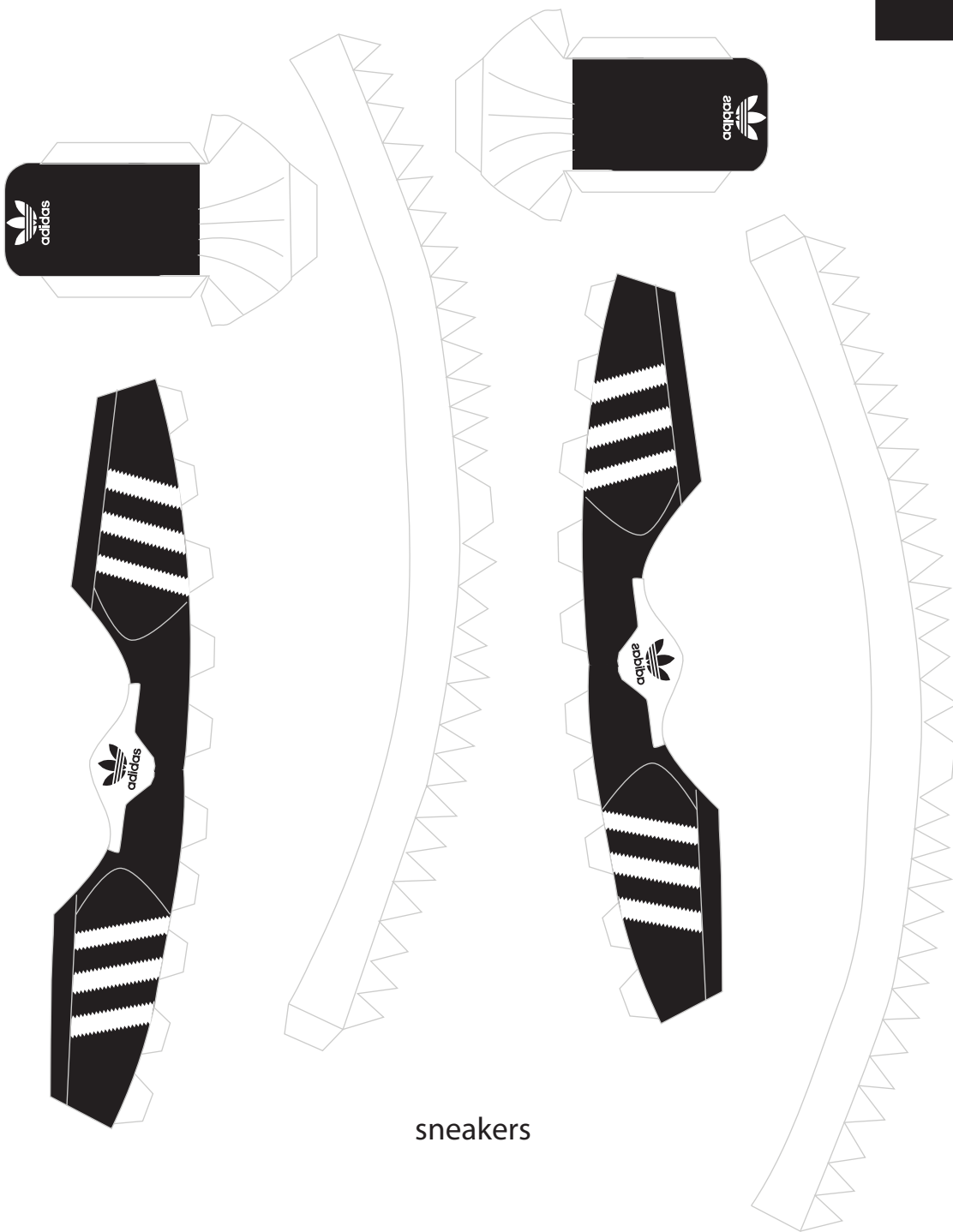
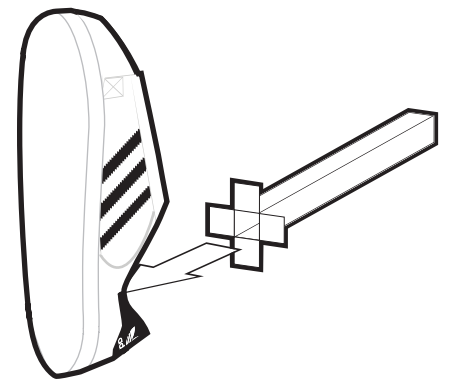
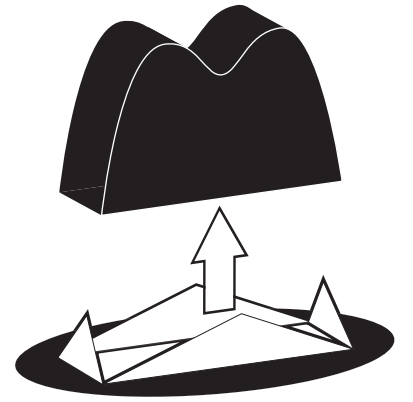

sneakers



the sole of the shoe is made with extra paper. once you get the shape of the shoe and glue it to the sole, you can trim off the rest.





# DMC

Darryl "D.M.C." Matthews McDaniels (born May 31, 1964) is one of the pioneers of hip hop culture and founding members of the legendary hip hop group Run-D.M.C. In 1978, McDaniels taught himself to DJ in the basement of his parents' home, using turntables and a mixer given to him by his older brother, Alford. Later that year, McDaniels sold his DJ equipment, after his friend Joseph "Run" Simmons acquired his own turntables and mixer. After Jam-Master Jay, who was the best DJ in their hometown of Hollis joined the group, Run encouraged McDaniels to rap rather than DJ. Gradually, McDaniels came to prefer rapping to mixing records, and adopted the nickname of "Easy D". In 1981, he dropped the "Easy D" moniker in favor of "DMcD", the way he signed his work in school, and then to the shorter "D.M.C.". D.M.C. alternately stood for "Devastating Mic Controller" or his nickname since childhood, "Darryl Mac".

— Wikipedia

\*I am not affiliated with RUN DMC, Def Jam Records, inc., or any related properties\*

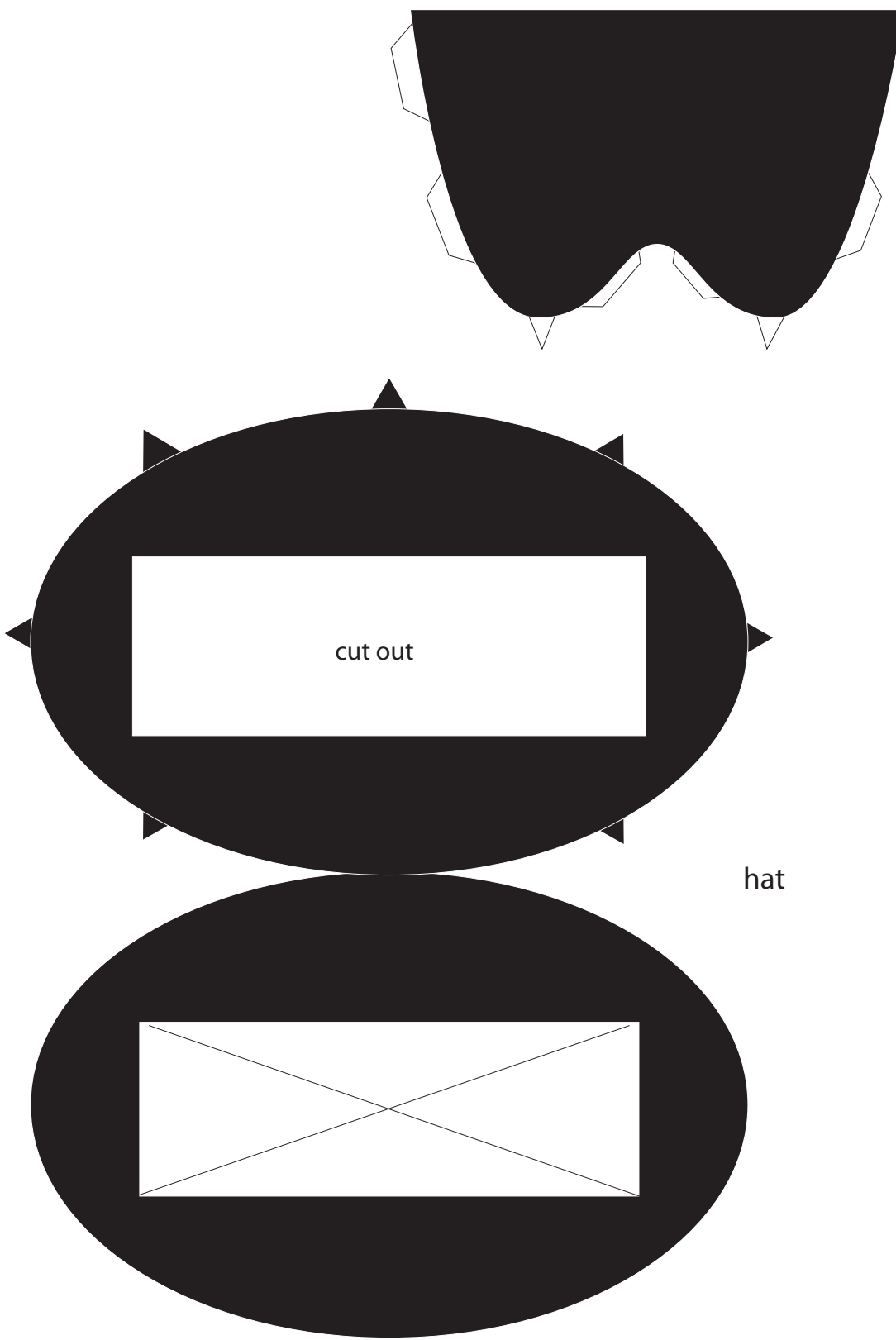

hat

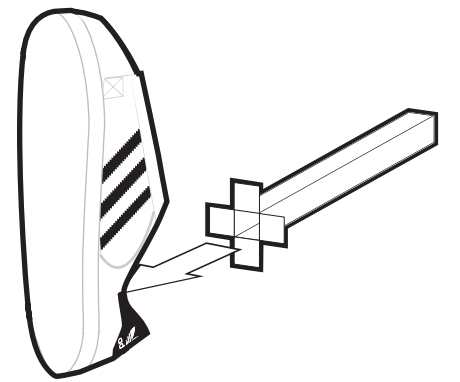
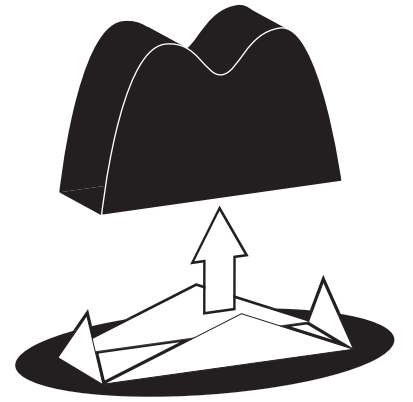

sneakers



the sole of the shoe is made with extra paper. once you get the shape of the shoe and glue it to the sole, you can trim off the rest.



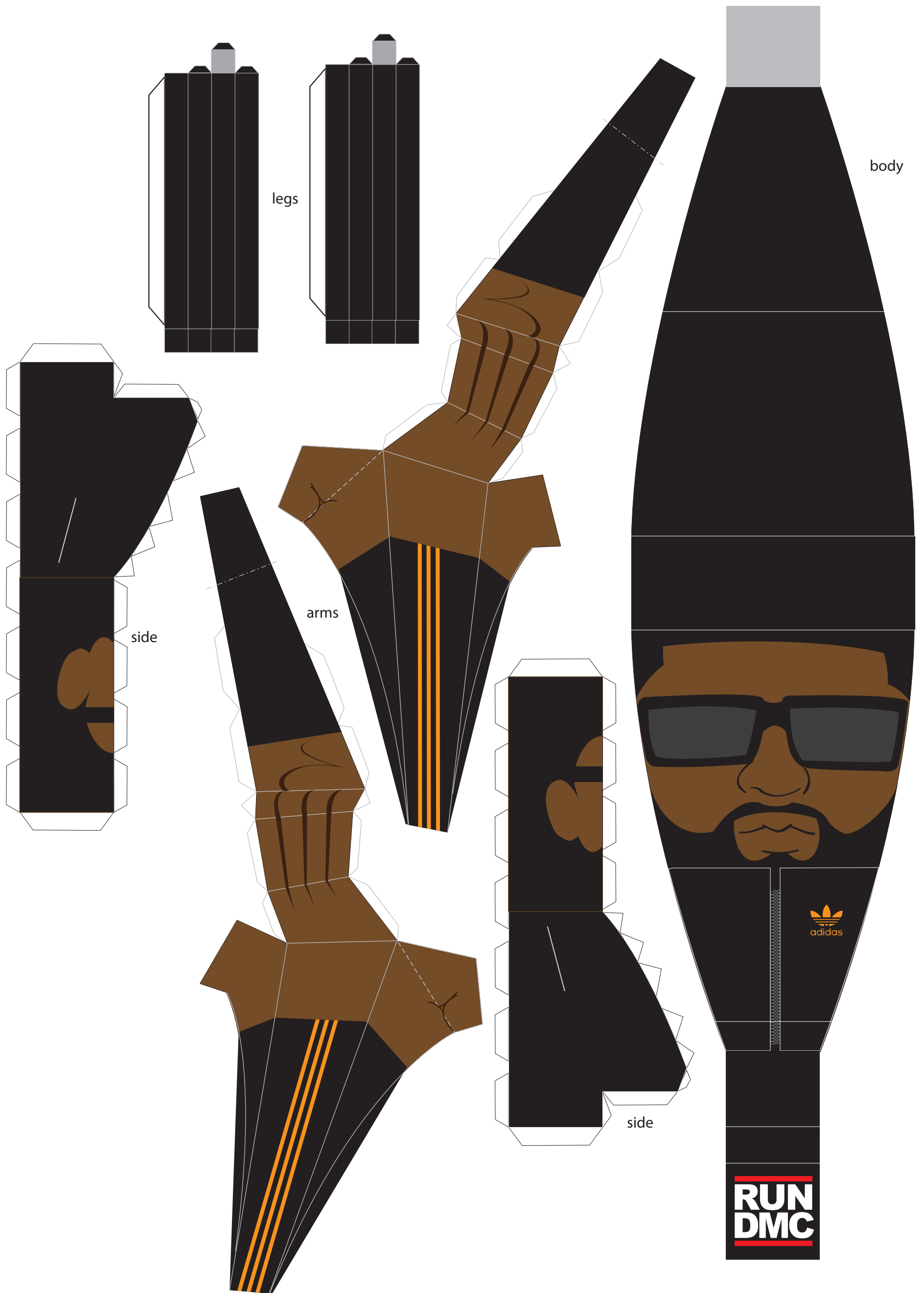

Mizell was born in Brooklyn, New York and moved to Queens at the age of 10 with his family. He played bass and drums in several garage bands prior to joining Run-D.M.C.; on all of their albums from Raising Hell on, he played keyboards, bass, and live drums in addition to his turntable work. Mizell remained in his childhood neighborhood his entire life. He founded the Scratch DJ Academy in Manhattan for children interested in DJing.

In 1989, Mizell established the label Jam Master Jay Records, which scored a strong success in 1993 with the band Onyx. He also connected Chuck D with Def Jam co-founder Rick Rubin. (Def Jam's other founder, Russell Simmons, is the brother of DJ Run.)

— Wikipedia



\*I am not affiliated with RUN DMC, Def Jam Records, inc., or any related properties\*

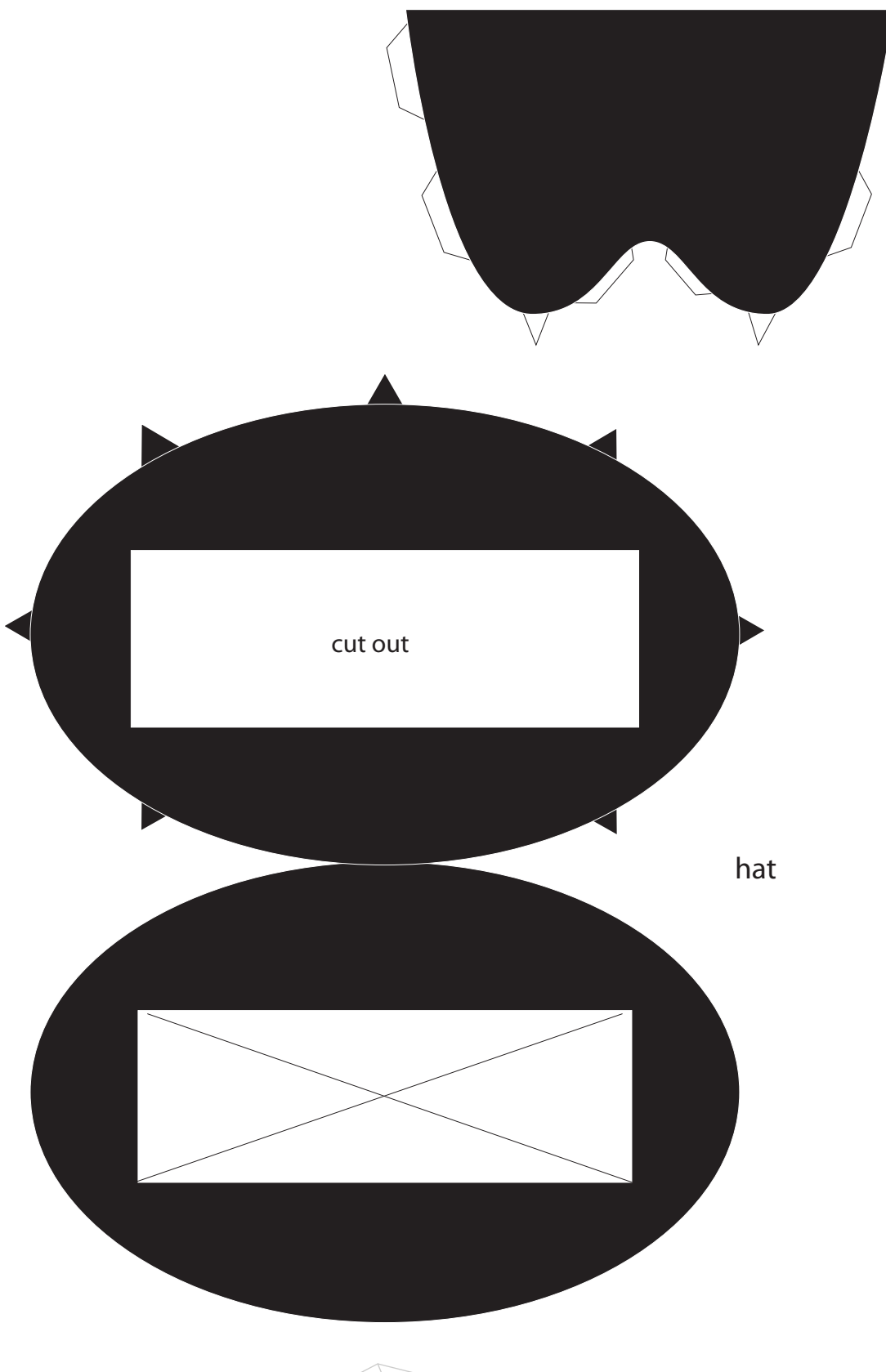

cut out

hat

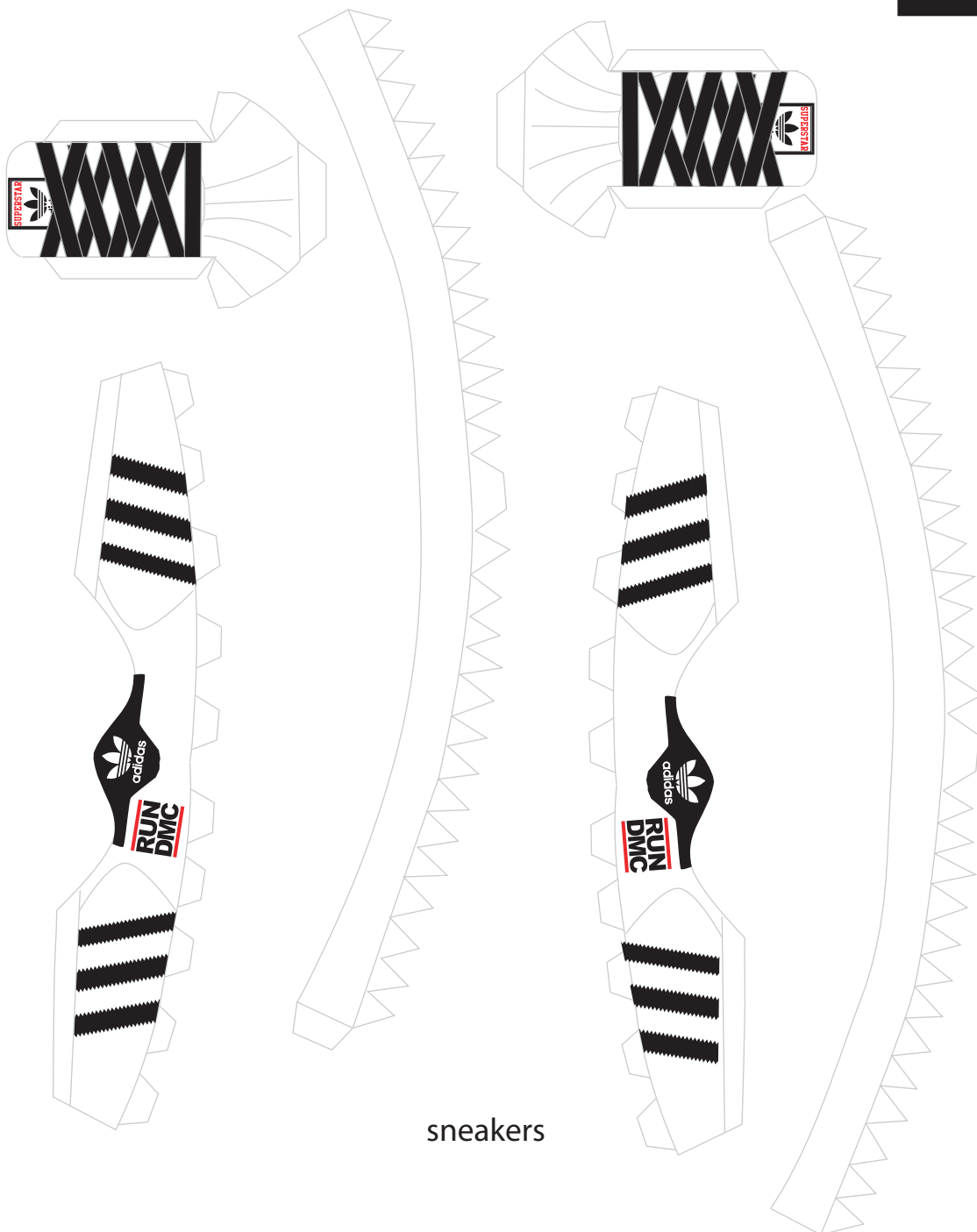
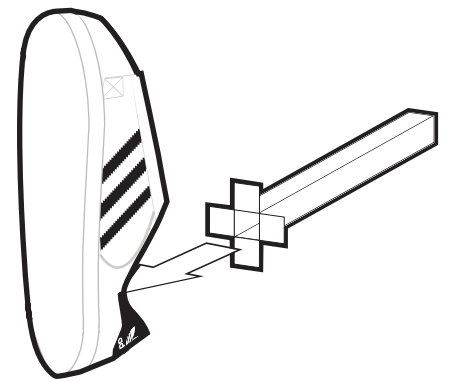
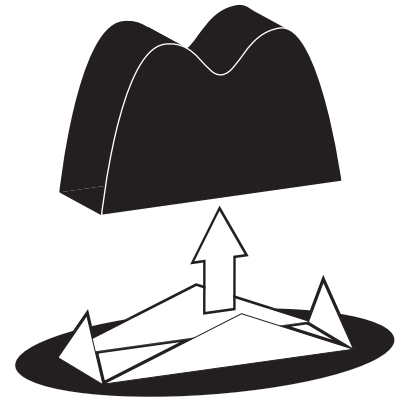

sneakers

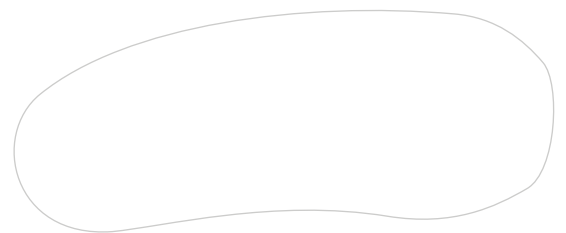

the sole of the shoe is made with extra paper. once you get the shape of the shoe and glue it to the sole, you can trim off the rest.





[www.bryanrollins.com](http://www.bryanrollins.com)

©2007-2009